

Effect of short high-frequency bipolar pulses on plasma membrane permeabilization

L4

Janja Dermol-Černe, Lea Vukanović

University of Ljubljana, Faculty of Electrical Engineering

Duration of the experiments: 60 min

Max. number of participants: 4

Location: Cell Culture Laboratory 2

Level: basic

PREREQUISITES

Participants should be familiar with Laboratory safety (S1) and Electroporation Hardware Safety (S2). No other specific knowledge is required for this laboratory practice.

THEORETICAL BACKGROUND

In electrochemotherapy and irreversible electroporation as ablation technique, square 50-100 μ s long monopolar pulses are usually applied at repetition frequency 1 Hz. The main drawbacks to the treatment of tissues with these monopolar pulses are discomfort and pain, the need to administer muscle relaxants and anesthesia, need for synchronization of the pulse delivery with the electrocardiogram and inhomogeneous tissue impedance. One of the possibilities to overcome these obstacles is high-frequency irreversible electroporation (HF-IRE). In HF-IRE, long monopolar pulses are replaced with bursts of a few μ s long bipolar pulses, which mitigate muscle contractions, however at the expense of delivering higher energy.

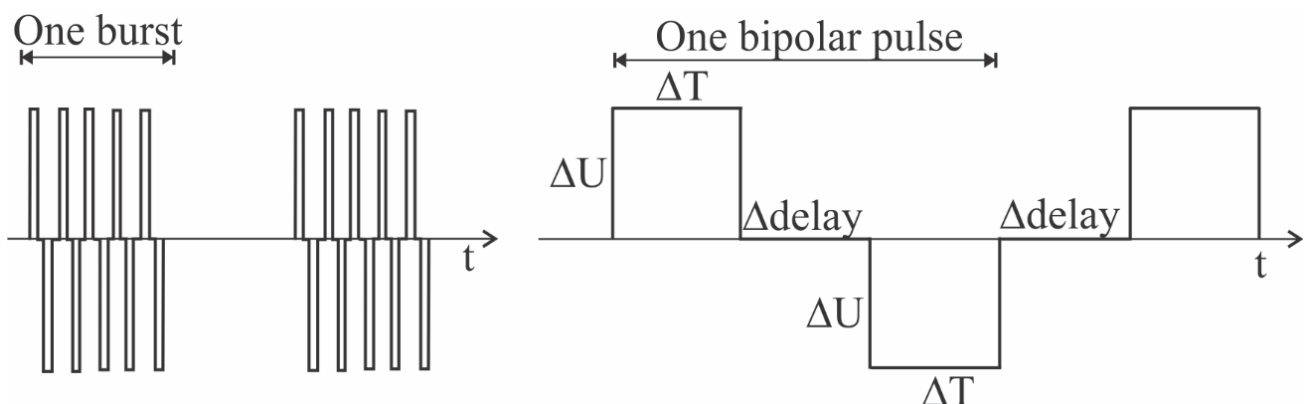

Figure 1: A typical waveform of pulses in the H-FIRE treatment. Pulses are usually delivered in several bursts delivered at repetition frequency 1 Hz. One pulse consists of a positive and a negative pulse and the delay between them.

The aim of this laboratory practice is the comparison of the effect of HF-IRE pulses and longer monopolar pulses on permeabilization of the plasma membrane as determined by spectrofluorometric measurements.

EXPERIMENT

We will detect electroporation on spectrofluorometer using propidium iodide. Propidium iodide (PI) is a red-fluorescent dye. It is not permeant to live cells and is commonly used to detect dead cells in a population. After plasma membrane permeabilization, however, PI can diffuse into cells. It binds to DNA with little sequence preference. After binding, its fluorescence is increased 20- to 30-fold, with excitation maximum at 535 nm and emission maximum at 617 nm.

We will determine the effect of the pulse amplitude of HF-IRE pulses on the degree of cell membrane permeabilization. We will deliver 50 bipolar pulses consisting of 1 μ s long positive 1 μ s long negative pulse with 1 μ s delay between them, delivered in 8 bursts at repetition frequency 1 Hz. We will compare the effect of the HF-IRE pulses on plasma membrane permeabilization with the monopolar pulses of parameters traditionally used in electrochemotherapy (8x100 μ s pulses, 1 Hz repetition frequency). Thus, the duration of all pulses of HF-IRE pulses as well as of monopolar pulses is 800 μ s.

We will use attached Chinese hamster ovary cells, 2.5×10^5 cells per well plated 24 hours in advance in 24 well plate. As the electroporation buffer, we will use 10 mM K_2HPO_4/KH_2PO_4 , 1 mM $MgCl_2$, 250 mM sucrose with 1.78 mS/cm, 292 mOsm/kg, and pH 7.4. We will use Pt/Ir wire electrodes with 0.8 mm diameter and 4 mm inter-electrode distance positioned at the bottom of the well. Between the electrodes, the electric field is approximately homogeneous and can be calculated as the ratio of the applied voltage and the inter-electrode distance.

For the application of pulses, we will use a laboratory prototype pulse HF-IRE pulse generator (University of Ljubljana) based on H-bridge digital amplifier with 1 kV MOSFETs (DE275-102N06A, IXYS, USA). We will monitor the delivered voltage and current by an oscilloscope, a differential probe and a current probe.

Protocol:

Remove the 24 well plate from the incubator and replace the growth medium with 300 μ l per well of electroporation buffer containing 0.15 mM PI. Apply electric pulses and leave the cells for 3 minutes at room temperature to allow PI to diffuse into cells then replace the buffer with 1 ml of fresh electroporation buffer to stop PI influx. Increase the pulse amplitude of the bipolar pulses from 400 V to 1000 V. For the comparison with monopolar pulses, deliver 8x100 μ s pulses with a repetition frequency of 1 Hz at 1000 V. As a negative control, apply no pulses to one well.

We will determine the fluorescence intensity spectrofluorometrically (Tecan, Infinite 200). Set the appropriate excitation and emission wavelengths for PI (535/617 nm). Plot a figure of fluorescence as a function of the electric field. Compare the fluorescence, obtained with the bipolar pulses, to the fluorescence, obtained with monopolar pulses of the same voltage.

FURTHER READING:

- D. C. Sweeney, M. Reberšek, J. Dermol, L. Rems, D. Miklavčič, and R. V. Davalos, "Quantification of cell membrane permeability induced by monopolar and high-frequency bipolar bursts of electrical pulses," *Biochim. Biophys. Acta BBA - Biomembr.*, vol. 1858, no. 11, pp. 2689–2698, Nov. 2016.
- C. B. Arena, M. B. Sano, M. N. Rylander, and R. V. Davalos, "Theoretical Considerations of Tissue Electroporation With High-Frequency Bipolar Pulses," *IEEE Trans. Biomed. Eng.*, vol. 58, no. 5, pp. 1474–1482, May 2011.
- C. Yao *et al.*, "Bipolar Microsecond Pulses and Insulated Needle Electrodes for Reducing Muscle Contractions During Irreversible Electroporation," *IEEE Trans. Biomed. Eng.*, vol. 64, no. 12, pp. 2924–2937, Dec. 2017.
- S. P. Bhonsle, C. B. Arena, D. C. Sweeney, and R. V. Davalos, "Mitigation of impedance changes due to electroporation therapy using bursts of high-frequency bipolar pulses," *Biomed. Eng. OnLine*, vol. 14, no. Suppl 3, p. S3, 2015.

NOTES & RESULTS

Bipolar/Monopolar	Bipolar	Bipolar	Bipolar	Bipolar	Bipolar	Monopolar
Voltage (V)	0	400	600	800	1000	1000
Pulse duration ΔT (μs)	0	1	1	1	1	100
Raw data (a.u.)						

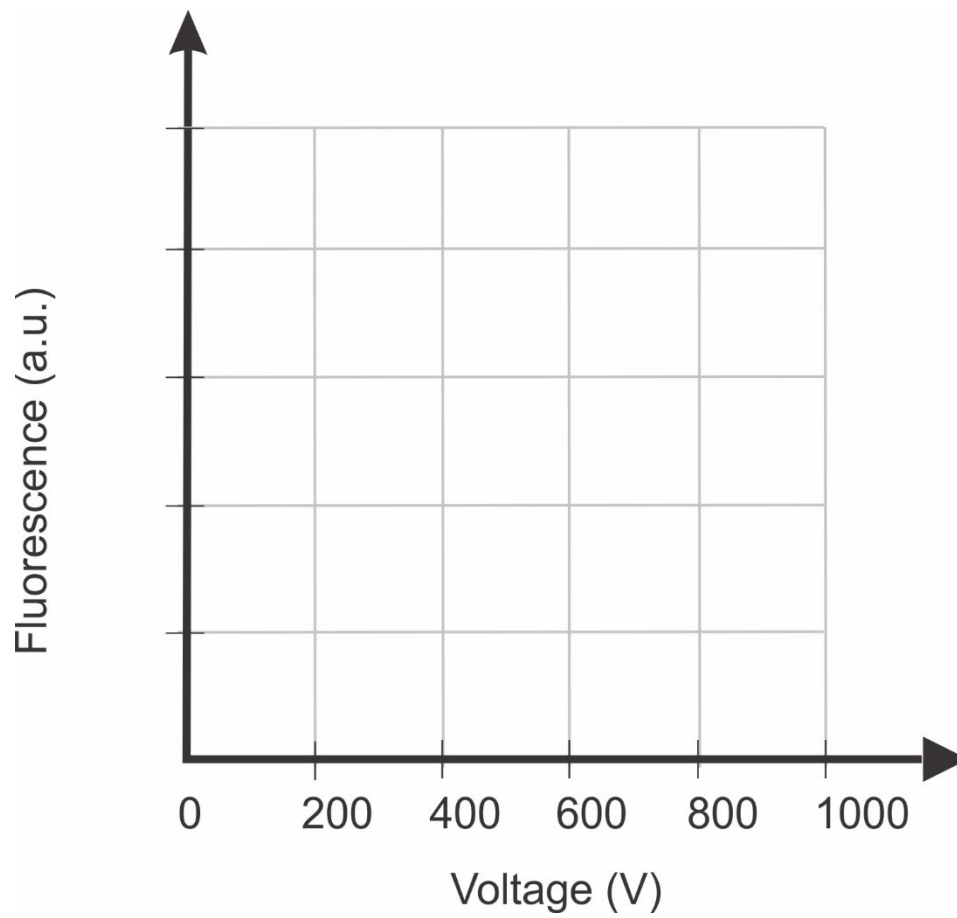

NOTES & RESULTS
